

STEYR MARINE ENGINES +MERCUISER BRAVO STERNDRIVE

170 - 184 KW (230 - 250 HP)

6-Cylinder

The state-of-the-art STEYR Marine Diesel Engine with dual cooling circuit fulfilling the strengthened future marine emission regulation.

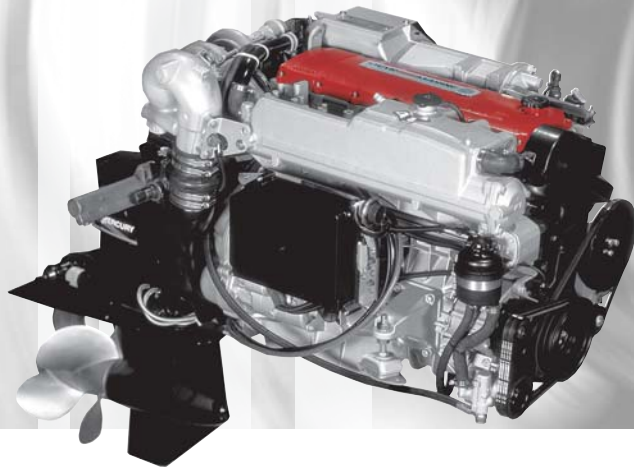

Hydraulic pump optional

The STEYR Marine Engine is designed for high performance. The innovative fuel injection technology enables an excellent torque and speed range. Therefore adaptation to existing marine propulsion systems can be performed easily.

Remarkable features of the STEYR Marine Engines are the dynamic behaviour and immediate response as well as the impressive acceleration.

SERVICE LIFE

The STEYR Marine Engines are manufactured using high alloy materials to provide enduring longevity for all running components. Using corrosion resistant materials for the entire seawater system as a standard in the dual circuit cooling system. Consequently designed solutions to meet the criteria of marine environment guarantee the best corrosion protection for any auxiliaries and electronic components in marine ambience.

COMFORT

The patented 2-stage UNIT INJECTOR fuel injection technology provides for a worldwide approved and smooth operation noise (patented). Noise emission levels are over the most important operating range below the running noise of gasoline engines. The additional elastic separation of the Monoblock against the aluminum casted engine housing reduces the engine related vibration transmitted into the hull therefore the noise level on board is further reduced. Torque and speed range characteristic enable optimal matching to individual application while maintaining transmission, gear ratio and propeller dimensions. The big choice of matched accessories fulfills the highest level of quality and comfort for you on board of your vessel.

EXHAUST EMISSIONS

The trend-setting UNIT INJECTOR system already enables us today to conform with the valid emission regulations BSO II and SAV 2, respectively we can fulfill the announced EPA – Tier 2 and suchlike emission regulations.

STERNDRIVE

STEYR Marine Engines and MerCruiser Stern-Drives are an ideal combination for your power boat. STEYR and MerCruiser put together an optimum package for best performance and offers you for your enjoyment STEYR engines with Bravo I, Bravo II and Bravo III Stern-Drives.

TECHNICAL DESCRIPTION

ENGINE MONOBLOCK

Our unique and robust monoblock design, engine block and cylinder head made from high grade alloy cast iron, without limitation in cooling and unrivaled roundness of the cylinder gives exceptional life time for the liner.

- Chrome-Molybdenum forged crankshaft, dynamically balanced
- Pistons are cast from high silicon aluminum, with oil cooling channel in 3-ring technology
- Hardened valve-seats high performance NIMONIC valve material
- Elastic coupling on flywheel, design matched depending on application

ENGINE MOUNTING

Adjustable front and rear silent blocks capable to take propeller thrust.

LUBRICATION SYSTEM

- Exchangeable oil filter cartridge
- Oil scavenger pipe through dipstick
- Closed crankcase breathing system

FUEL SYSTEM

- Integrated high pressure UNIT INJECTOR with dual stage fuel-injection technology, operated by overhead camshaft and rocker arms.
- Electric fuel pump (automatic bleeding capability)
- Exchangeable fuel filter cartridge

EXHAUST SYSTEM

Freshwater cooled exhaust manifold and seawater cooled exhaust elbow

COOLING SYSTEM

- Freshwater cooling system with thermostat control
- Heat exchanger with integrated expansion tank system
- Connection prepared for boiler/cabin heating system
- Sea water pump with impeller, integrated and replaceable wear plates

STEYR MARINE ENGINES + MERCUISER BRAVO STERNDRIVE

TECHNICAL DATA

Engine type	MO236K42	MO256H45
	4-stroke, turbocharged, intercooled direct-injection, fresh water cooling	
Output (crankshaft) kW [HP]*	170 (230)	184 (250)
Rpm at full load	4300	4500
Cylinders	6 in line	6 in line
Displacement [cm ³]	3200 (195 cid)	3200 (195 cid)
Bore [mm]	85 (3.35')	85 (3.35')
Stroke [mm]	94 (3.7')	94 (3.7')
Compression ratio	18 : 1	17 : 1
Max. torque [Nm]	450	500
at speed [rpm]	2800	2800
[lb-ft]	331	332
Injection system	2 stage unit injectors	2 stage unit injectors
Standard alternator [A]	90	90
Electronic engine diagnostic	yes	yes
Weight [kg]	305 (671 lbs)	322 (708.4 lbs)
Weight per unit of power [kg/HP]	1.44 (3.19 lbs/HP)	1.29 (2.84 lbs/HP)

STERNDRIVE

MerCruiser	Bravo I, II, III	Bravo I, II, III
Propeller	DuoProp (SST optional)	DuoProp (SST optional)
Gear ratio	1.65/1.81/2.0/2.2/2.43	1.65/1.81/2.0/2.2/2.43
Dry weight [kg]	113 (226 lbs)	113 (226 lbs)

ELECTRICAL SYSTEM

- 12V system plug-in solution
- 2-Pole installation (optional)
- Marine suitable alternator 14V/90 A
- Voltage regulator in alternator cares for optimum charging conditions of the batteries
- Glow plugs for a trouble-free cold start
- Extension cable with plug-in-connection available in various lengths and for fly bridge installations

INSTRUMENT PANEL

Standard panel includes:

- Key switch – ignition and start function
- Control lamps for battery charging, oil pressure, glow plug indication and service code storage
- Revolution counter with hourmeter
- Temperature gauge for engine coolant temperature
- Instrument illumination
- Audible alarm

NEW (optional): The STEYR Control Center an integrated display unit including the functions of digital instruments, switch board, fuel management & driving range calculation, GPS-position, speed over ground, digital manual and diagnostic system.

STERNDRIVE

Selection of STEYR Engines and MerCruiser Bravo I, Bravo II and Bravo III Stern Drives and with gear ratio from 1.50/1.65/1.81/2.00/2.20/2.43 : 1
Please consult your STEYR dealer for optimum match of gear ratio for your boat and application.

- Adaptation kits for the most used available sterndrives.

Water pick up, sea cock, siphon valve, cooling hose, exhaust system and transom exhaust, fuel filter and fuel pipes, pulleys, filler cap and brackets for auxiliaries - just contact your STEYR Marine Partner he will be delighted to serve you.

Not all models, standard equipment and accessories are available in all countries.
All specifications are subject to change without notice.

The engine illustrated may not be entirely identical to production standard engines.

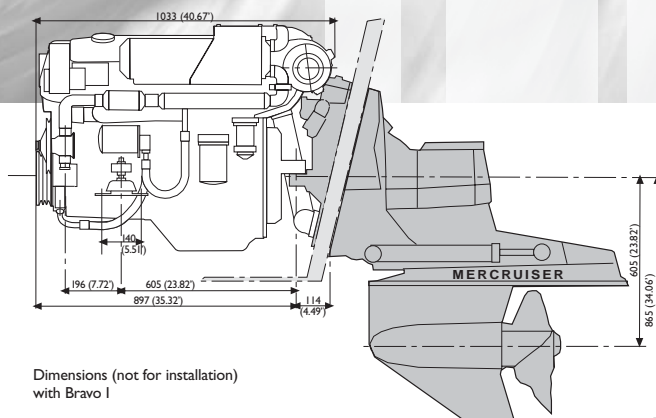
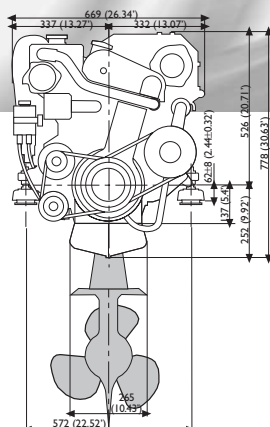

Dimensions (not for installation)
with Bravo I

ACCESSORIES / OPTIONS

- Oil pressure gauge
- Additional key switch for governed speed
- Connecting cable for secondary helm
- Extra alternator kits
- Hot water systems
- Separate expansion tanks
- Sea water filters
- Front power take off
- Fuel pre-filter with water separator
- Chemical products – paints, oils, cleaners etc.

Your partner

STEYRMOTORS
INNOVATION WITH LIGHTNESS

